

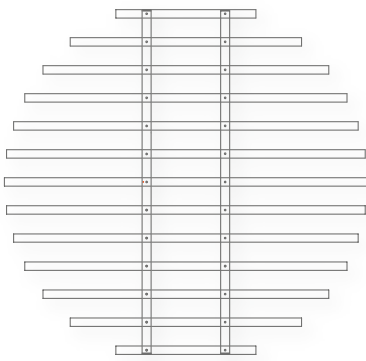

Baffle at its best



**OWA**



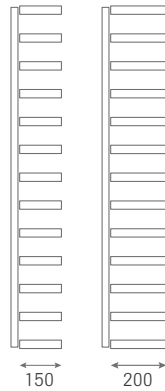

Cloud 150 | 200



Section

## Technical data | Mineral tiles

<b>Dimensions and weight</b>	Height: 150 mm   Diameter: 1300 mm   Weight: approx. 16.0 kg Height: 200 mm   Diameter: 1300 mm   Weight: approx. 20.0 kg
<b>Material</b>	Mineral tile with fleece cover
<b>Design</b>	Sinfonia
<b>Reaction to fire</b>	A2-s1,d0 in accordance with EN 13501-1
<b>Edge</b>	 3
<b>Colour</b>	White
<b>Thickness</b>	Approx. 30 mm (OWAcoustic premium)
<b>Sound absorption</b>	 $\alpha_w = 0.65$   NRC = 0.65
<b>Moisture resistance</b>	 up to 95 % RH
<b>Metal suspension and weight</b>	All metal components listed are galvanized steel or white coated galvanized steel respectively   Weight: approx. 3.0 kg
<b>Suspension depth</b>	From top edge of the baffle tile to bottom edge of the concrete 50 mm

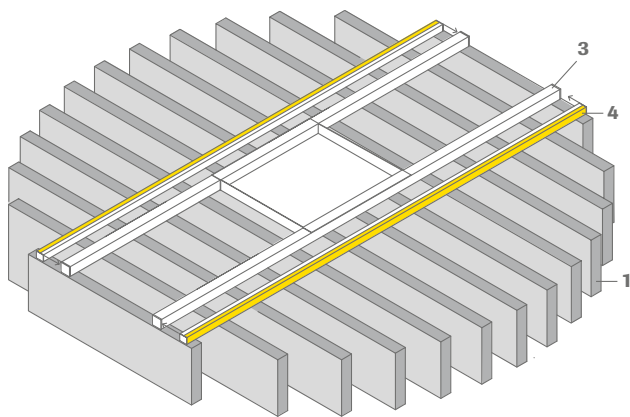

Cloud 150

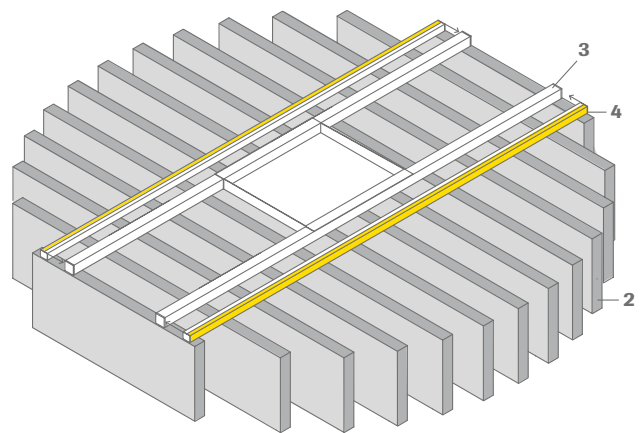

Cloud 200

### Cloud | Content baffle tile package

Package	Description / dimensions / surface	Units / package
1 Cloud 150	Baffle, height: 150 mm, length: 1295 mm, Sinfonia	1 pce
	Baffles, height: 150 mm, length: 1280 mm, 1230 mm, 1150 mm, 1020 mm, 825 mm, 500 mm, Sinfonia	2 pcs each
2 Cloud 200	Baffle, height: 200 mm, length: 1295 mm, Sinfonia	1 pce
	Baffles, height: 200 mm, length: 1280 mm, 1230 mm, 1150 mm, 1020 mm, 825 mm, 500 mm, Sinfonia	2 pcs each

### 3 Cloud | Content construction package



Description / dimensions / surface	Units / package
Square tube 25 x 25 x 2.0 mm, length approx. 1220 mm, colour: white, fully assembled with connector bar	2 pcs
Connector bar 305 x 200 x 1.0 mm, white	1 pce
End cap of C-carrier section, plastic, colour: white, fully assembled with square profile	4 pcs
Spacer sleeve M6 x 25 mm, white for direct installation	4 pcs
Fixing plug, Ø 11.6 mm, white, for square profile keyholes	26 pcs
Threaded sleeve M6 x 30 mm, for suspended installation	4 pcs
M6 x 14 mm, galvanised, for suspended installation	4 pcs

### 4 Cloud LED | Components of light package

Description / dimensions / surface	Units / package
LED profiles, length: 1160 mm, wide: 26 mm, height: 24 mm, IP 20, 12 W/m (4000 K) or 14.4 W/m (RGB) incl. the necessary cabling light colour neutral white 4000 K or RGB	2 pcs
Fastening clips with each 2 drill-holes, plastic	4 pcs
Transformer for LED light package neutral white (4000 K) + RGB	1 pce
RGB control unit (1 piece per light package or series connection)	1 pce
RGB repeater for series connection only (unit = amount of light packages per row - 1)	1 pce
RGB remote control (1 remote control per row for series connection)	1 pce

The LED profiles (4) are fastened to the square profiles of the Cloud construction package (3) using the included fastening clips. Thread the ready-made cable through the square profile and connect it to the transformer. The transformer is placed on the body of the Cloud's hanger structure (3). Ask your electrical contractor to connect the Square to the power supply.

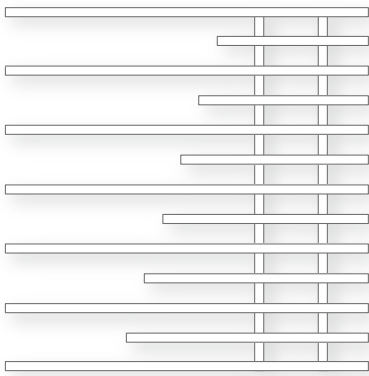

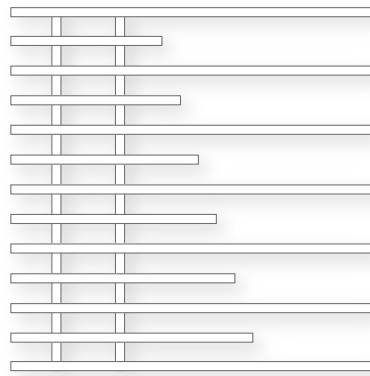

Square 150 | 200



Section

## Technical data | Mineral tiles

<b>Dimensions and weight</b>	Height: 150 mm, 200 mm   Dimension: 1230 x 1200 mm   Weight: approx. 18.0 kg
<b>Material</b>	Mineral tile with fleece cover
<b>Design</b>	Sinfonia
<b>Reaction to fire</b>	A2-s1,d0 in accordance with EN 13501-1
<b>Edge</b>	3
<b>Colour</b>	White
<b>Thickness</b>	Approx. 30 mm (OWAcoustic premium)
<b>Sound absorption</b>	 $\alpha_w = 0.65$   NRC = 0.65
<b>Moisture resistance</b>	 up to 95 % RH
<b>Metal suspension and weight</b>	All metal components listed are galvanized steel or white coated galvanized steel respectively   Weight: approx. 3.0 kg
<b>Suspension depth</b>	From top edge of the baffle tile to bottom edge of the concrete 50 mm

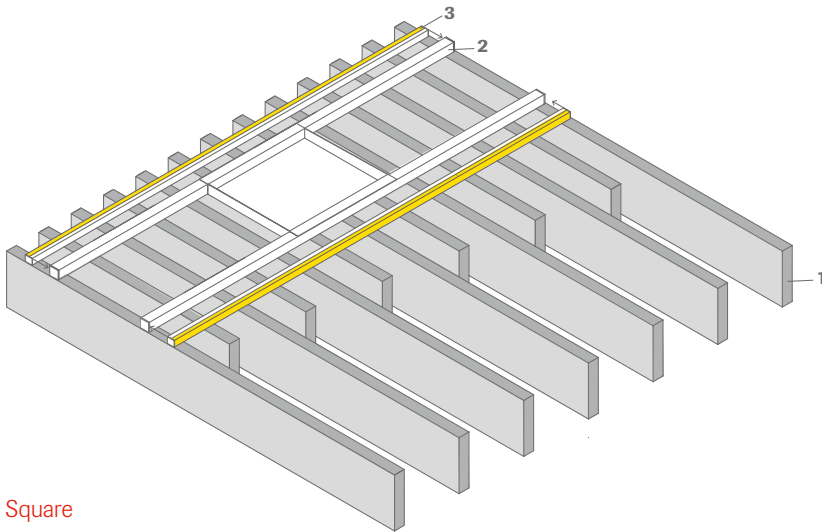

Square

### 1 Square | Content baffle tile package

Description / dimensions / surface	Units / package
Baffles, height: 150 mm, length: 1200 mm, Sinfonia	7 pcs
Baffles, height: 200 mm, length: 830 mm, 780 mm, 730 mm, 675 mm, 620 mm, 570 mm, Sinfonia	1 pce each

### 2 Square | Content construction package



Description / dimensions / surface	Units / package
Square tube 25 x 25 x 2.0 mm, length: approx. 1220 mm, colour: white, fully assembled with connector bar	2 pcs
Connector bar 305 x 200 x 1.0 mm, white	1 pce
End cap of C-carrier section, plastic, colour: white, fully assembled with square profile	4 pcs
Spacer sleeve M6 x 25 mm, white for direct installation	4 pcs
Fixing plug, Ø 11.6 mm, white, for square profile keyholes	26 pcs
Threaded sleeve M6 x 30 mm, for suspended installation	4 pcs
M6 x 14 mm, galvanised, for suspended installation	4 pcs

### 3 Square LED | Components of light package

Description / dimensions / surface	Units / package
LED profiles, length: 1160 mm, wide: 26 mm, height: 24 mm, IP 20, 12 W/m (4000 K) or 14.4 W/m (RGB) incl. the necessary cabling light colour neutral white 4000 K or RGB	2 pcs
Fastening clips with each 2 drill-holes, plastic	4 pcs
Transformer for LED light package neutral white (4000 K) + RGB	1 pce
RGB control unit (1 piece per light package or series connection)	1 pce
RGB repeater for series connection only (unit = amount of light packages per row - 1)	1 pce
RGB remote control (1 remote control per row for series connection)	1 pce

The LED profiles **(3)** are fastened to the square profiles of the Square design package **(2)** using the included fastening clips. Thread the ready-made cable through the square profile and connect it to the transformer. The transformer is placed on the body of the Square's hangar structure **(2)**. Ask your electrical contractor to connect the Square to the power supply.

**Tip:** LED lighting package should be installed before installation of baffle tiles.

## Direct installation of the sub construction

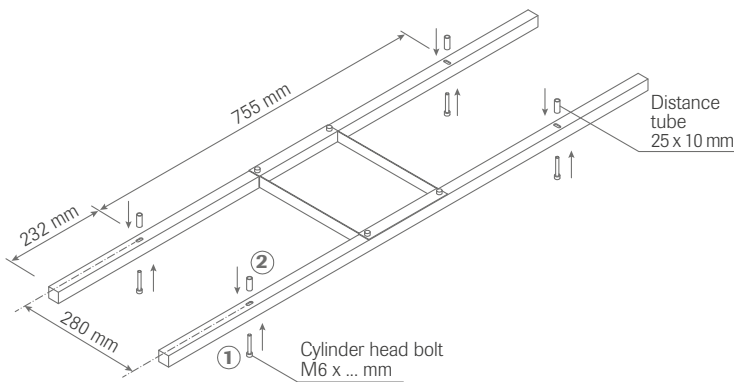

1. Insert the cylinder head bolt from below through the key hole drilling (length of the bolt depends on the fixing material).
2. Stick the distance tube on the screw shaft.
3. Screw the bolt into the anchor.

Only generally approved fixing materials have to be provided directly on site by the contractor!

## Suspended installation of the sub construction

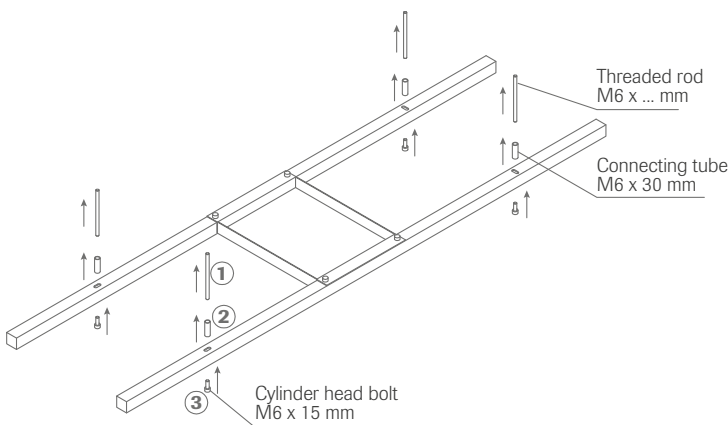

1. Insert the threaded rod into the fixing material.
2. The connecting tube has to be screwed up to the middle of the threaded rod.
3. Insert the cylinder head bolt from below through the key hole drilling and screw it into the connecting tube.

Only generally approved fixing materials and threaded rods have to be provided directly on site by the contractor!

**Important information:** Important information: Suspension height for Square max. 400 mm. All the rest of them have to be suspended with an additional, nonspillable subconstruction.

## Installation of the LED lighting package (optional)

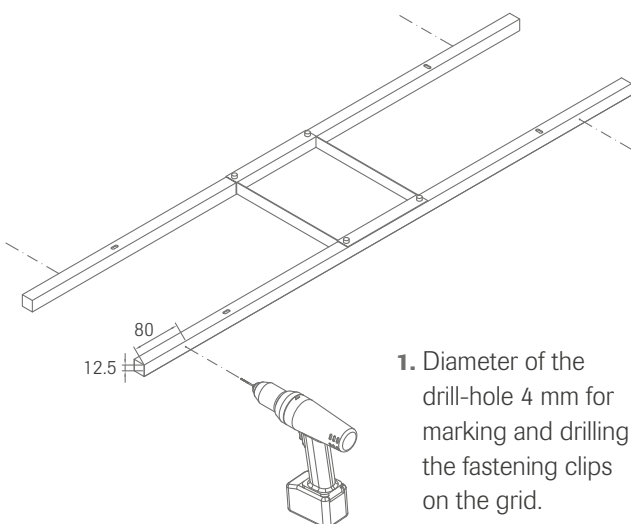

1. Diameter of the drill-hole 4 mm for marking and drilling the fastening clips on the grid.

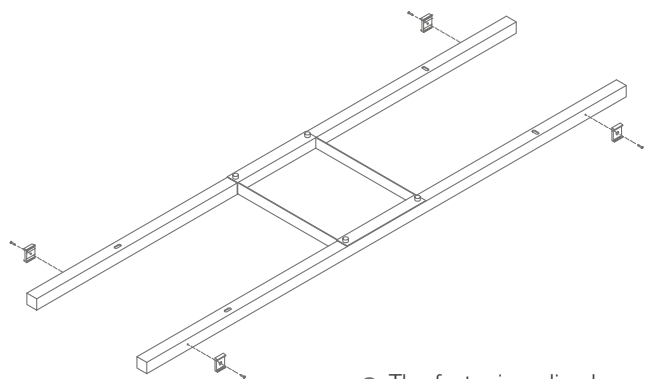

2. The fastening clips have to fix on the grid with the screws M 4 x 18 mm.

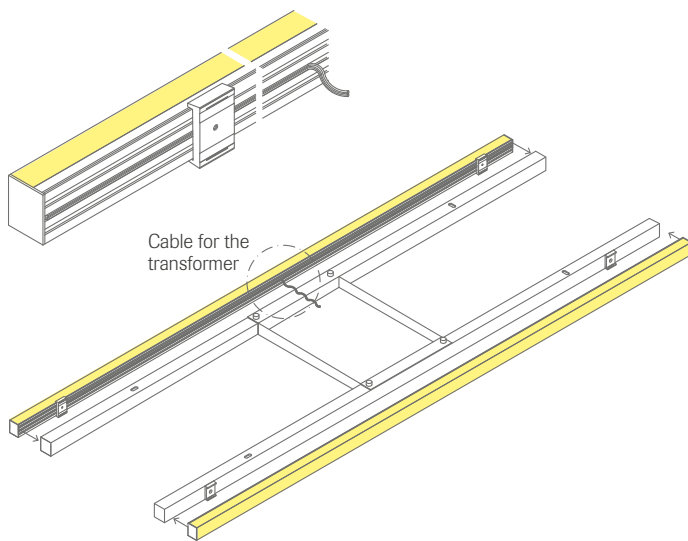

3. Fix the LED bars with their lower notch on the mounting clips and connect them. Connection of cables with the power transformer and electrical power supply must be done by an electrically skilled person. The cable must be pushed into the groove on the back. Put cable and power transformer on connector bar. Cable for connection to electrical power supply isn't included in LED lighting package.

## Installation of the baffle tiles

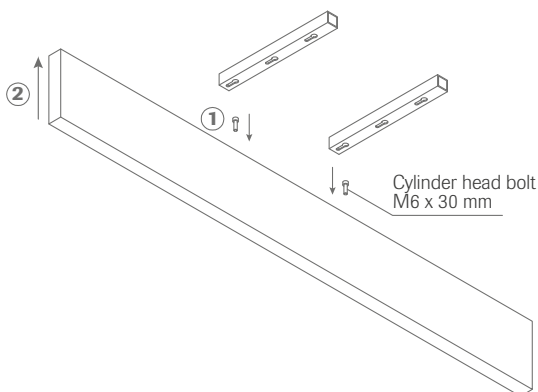

1. Cylinder head bolt M6 x 30 mm are pre-assembled with each baffle tile.
2. Insert the baffle tile including the screw heads into the key hole drillings.

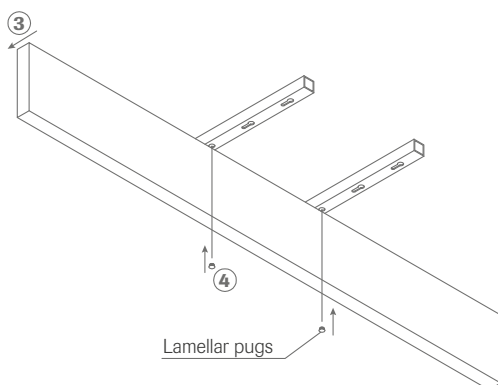

3. Move the screws into the slots of the key hole drillings by pushing the baffle tile.
4. Insert the plugs into the visible part of the key hole drillings.

### Hint:

Please take into consideration that during the installation of OWAcooustic elements wind pressure or wind suction can occur. In these cases all relevant measures of protection have to be taken.



## Product warranties

The information provided in this leaflet is based on the standards and data available at the time of publication. Any performance, warranties or guarantees provided, expressed or implied, are subject to the exclusive use of OWA components and the installation of those components in accordance with our recommendations. Failure to adhere to these conditions will result in the invalidation of any performance claims, warranties or guarantees and rejection of any liability. OWA reserves the right to make any technical improvements to the products, systems or services without prior notice. **All goods and services are supplied in accordance with our current Terms and Conditions of Sale.** Errors excepted!



# OWA

The information in this brochure is up-to-date at the time of publication. Errors and mistakes excepted. Please contact our competence team OWAconsult for specific advice. Our experts will be happy to answer your questions under the following contact details: tel: +49 9373 201-444 or e-mail: [info@owaconsult.de](mailto:info@owaconsult.de)

### Odenwald Faserplattenwerk GmbH

Dr.-F.-A.-Freundt-Straße 3 | 63916 Amorbach | Germany  
tel +49 9373 201-0 | [info@owa.de](mailto:info@owa.de)  
[www.owa-ceilings.com](http://www.owa-ceilings.com)